

ULTRA LOW NOISE

Y and Z Axis Hall Probe system

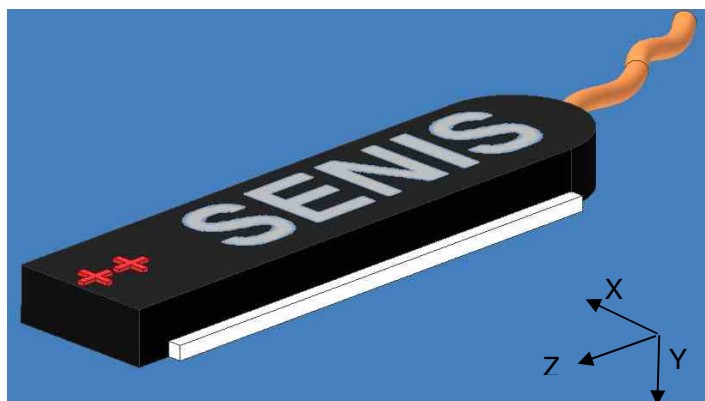

Key Features	
▪ Probe dimensions	1.5 x 5 x 16.5 mm ³
▪ Orthogonality of Axes	< ± 2° typ.

Description

SENIS's J-YZb-xx is a 2-Axis Hall-Probe System that gives an analog voltage output for each of the two components of the measured magnetic flux density and for the probe temperature. The device contains two high-resolution Hall elements and temperature sensors.

The sensors are embedded in the probe package and connected to the CaH. The probe is glued onto a reference ceramic plate suitable for an appropriate positioning and fixing of the probe.

J-YZb-xx Probe system

- Low noise (allowing high resolution measurements)
- Measurement of Y and Z magnetic field components with a high angular accuracy and high spatial resolution
- Virtually no planar Hall effect
- Negligible inductive loops
- The probe provides a temperature signal for an efficient compensation of temperature effects.
- Fixed (non-detachable) CaH cable connection to the transducer's electronic module

Dimensional Drawing

Depending on design, the probe itself can be as short as 15 mm and placed into a suitable probe holder of 30 mm length or longer. The sensor positions (mutual and with respect to the probe head) remain the same in both configurations.

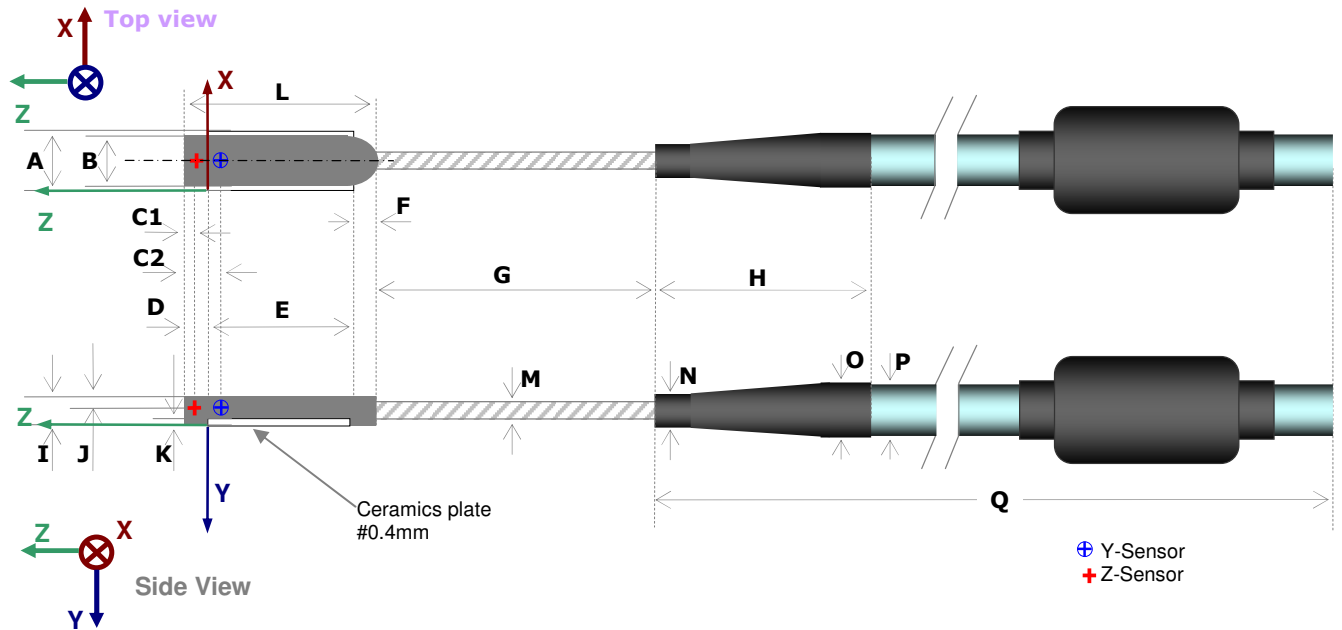

Probe & Cable Dimensions:

Probe Dimensions [mm]		Cable Dimensions [mm]	
A	5.0	G	200
B	4.0	H	35 ± 3
C1	0.55	I	1.5
C2	1.75	J	0.75
D	1.0	K	0.4
E	13.5	L	16.5
F	2.0		
		M	1.0 ± 0.2
		N	4.0 ± 0.2
		O	6.0 ± 0.2
		P	5 ± 1
		Q	2000±1%

Figure 1: Dimensions of the SENIS J-YZb-xx Hall probe (all measures are shown in mm). Red cross denotes Z-sensor and the blue circled-cross denotes the Y-sensor. The length of the reference ceramics can be extended to facilitate fixation and handling (shown by dotted ceramics part).

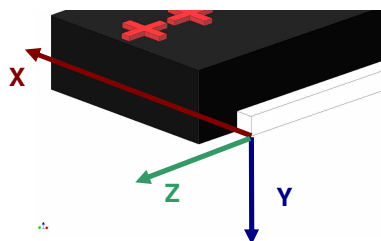

Figure 2: Reference Cartesian coordinate system of the SENIS J-YZb-xx Hall probe.

Specifications

Parameter	X(mm)	Y(mm)	Z(mm)
Dimensions			
▪ Field sensitive volume (FSV) diameter		0.3	0.3
▪ Position of the FSV center of Z-sensor	2.5	-0.75	0.45
▪ Position of the FSV center of Y-sensor	2.5	-0.75	-0.75
▪ Total probe external dimensions	5.0	1.5	16.5
Accuracy of positioning			
▪ Mutual angular accuracy of axes	Better than 2°(mutual orthogonality)		
▪ Angular accuracy of axes with respect to the reference surface	±2°, Determined during calibration		
General properties			
▪ Cable	Shielded, with a flexible thin part near the probe (see Fig.1)		

Installation Manual for the Probe J-YZb-xx

Although the probe is very robust with respect to its size, it should be handled with special care. Considering that we deal with a high-precision device of very small dimensions, following precautions should help to avoid damage to the probe during installation and handling, and ensure that the device's accurate calibration remains preserved.

The mounting of the probe should be carried out by application of very low pressure to its head and thin wires. If the probe head is clamped, the user needs to make sure that the environment surface in contact with the reference plane of the probe is flat and covers as much of the probe reference surface as

possible. Do not apply more force than required to hold the probe in its mounting. In order to prevent rupture of the thin wires from the probe head, the user should fix and secure the probe cable in the proximity of the head. The thin wires of the flexible section of the probe need to be folded with care; repeated strong bending should be avoided.

Caution

The probe tip is fragile; it should not come into a hard mechanical contact with other objects! Take off the protective cap only if the FSV (Field Sensitive Volume) of the probe otherwise cannot be placed at the desired position