

The **3H0.5x2x42-xx** is a very thin (0.5mm) and long (42mm) integrated 3-Axis Hall-Probe System. The core of the device is a silicon sensor chip (based on CMOS technology), which contains Hall elements, biasing circuits, amplifiers, and a temperature sensor. The probe gives a high-level analogue voltage output for each of the three components of the measured magnetic flux density, and for the chip temperature.

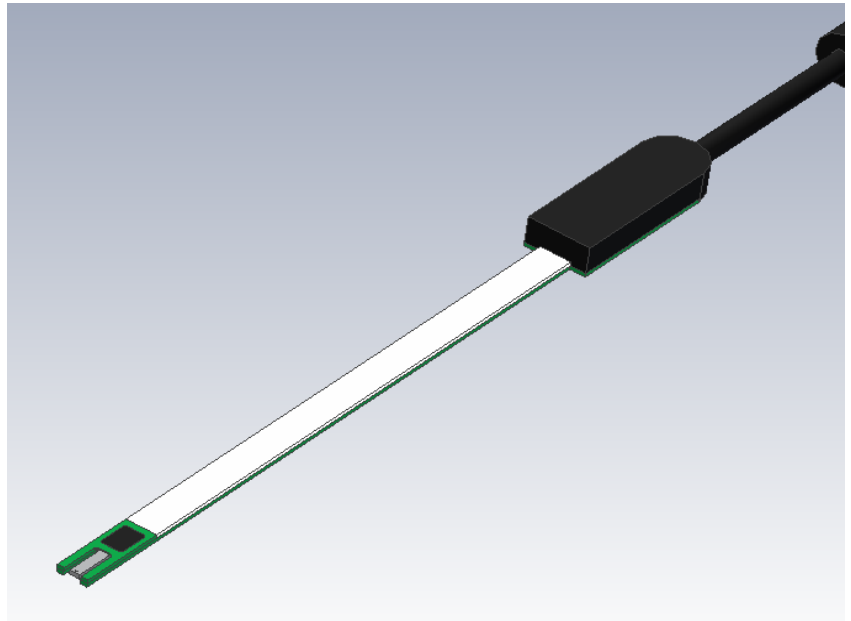

KEY FEATURES OF THE 3H05x2x42-XX PROBE SYSTEM

The unique advantages of the probe include:

- Thickness: 0.5 mm; length: 42 mm;
- Measurement of all three magnetic field components with a high angular accuracy and high spatial resolution;
- Virtually no planar Hall Effect;
- Negligible inductive loops, and
- The probe provides a temperature signal for an efficient compensation of temperature effects.

The sensor chip of the 3H05x2x42-xx is embedded in the probe package and connected to the CaH cable (see Figure 1).

The 3H05x2x42-xx Hall probe is available as a *Module H* of a SENIS Magnetic Field Transducer (see Transducer data-sheets on http://www.senis.ch/new-transducer_data_sheets.html).

Two connection options of the probe to the module E of the transducer are available:

- Detachable *CaH* cable connection to the transducer's electronic module (connector D-SUB25/F);
- Fixed (non-detachable) *CaH* cable connection to the transducer's electronic module.

The 3H05x2x42-xx is also available as a separate unit for OEM customers.

SENIS GmbH Technoparkstrasse 1, CH-8005, Zürich Web : www.senis.ch ; Email: info@senis.ch Phone: +41(79) 366 8756; Fax:+41(43)205 2638	North America: GMW Associates 955 Industrial Road, San Carlos, CA 94070, USA Web: www.gmw.com ; Email: sales@gmw.com Phone: +1 (650)802 8292; Fax:+1(650)802 8298	Rev.02, Feb. 2010
		Page 1 / 4

PROBE DIMENSIONS & CHARACTERISTICS

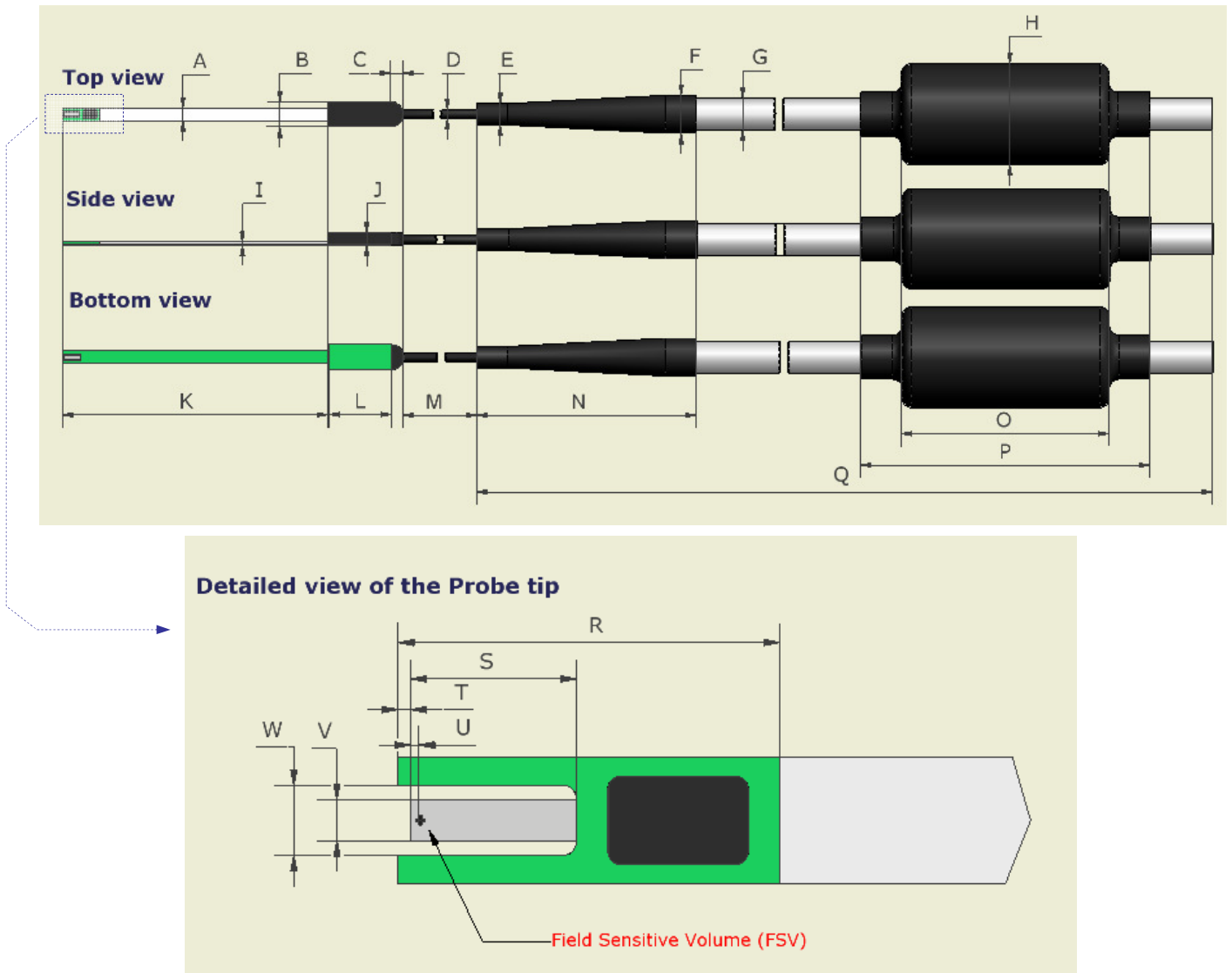

Probe and Cable Dimensions & Tolerances							
Dimension	[mm]	Dimension	[mm]	Dimension	[mm]	Dimension	[mm]
A	2.0 ± 0.1	G	4.8 ± 0.2	M	50 ± 1	S	2.8 ± 0.1
B	4.0 ± 0.1	H	16 ± 1	N	35 ± 3	T	0.2 ± 0.1
C	2.0 ± 0.1	I	0.5 ± 0.1	O	30 ± 1	U	0.15
D	1.5 ± 0.2	J	2.0 ± 0.1	P	50 ± 2	V	0.64
E	3.8 ± 0.2	K	42.3±0.2	Q	XX±1% ¹⁾	W	1.1 ± 0.1
F	6.0 ± 0.2	L	10.0±0.1	R	6.0 ± 0.1		

Figure 1: The dimensions of SENIS's 3H05x2x42-xx Hall probe and Cable (Module H)

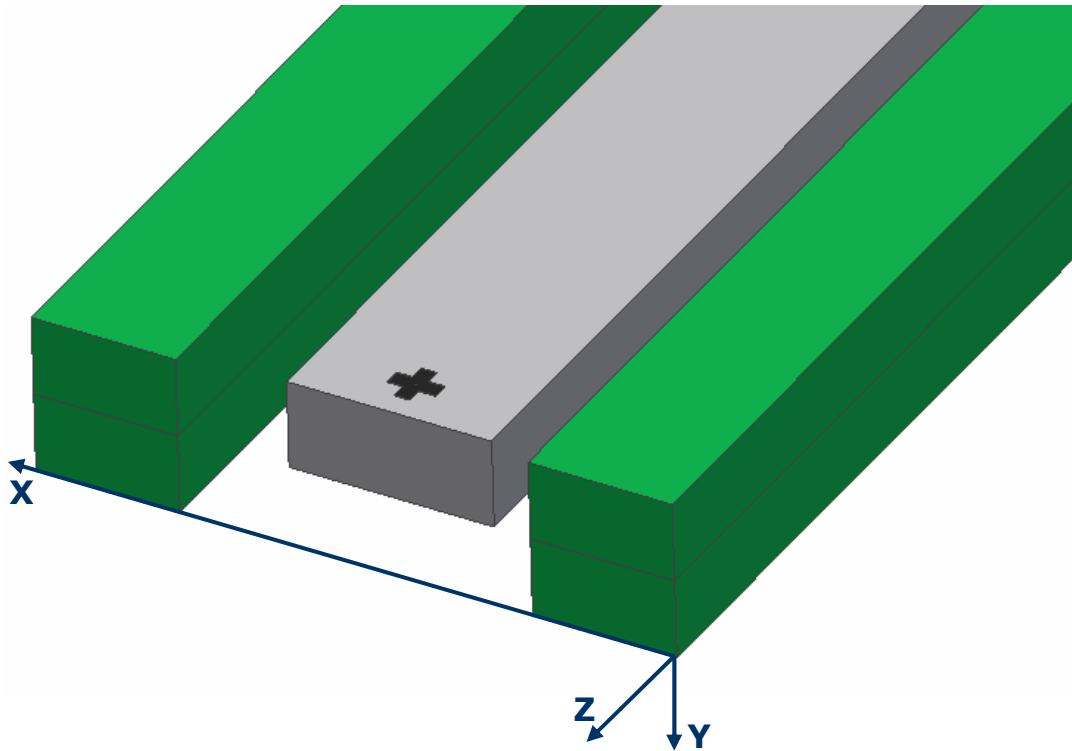

Figure 2: The reference Cartesian coordinate system of the SENIS's 3H05x2x42-xx Hall probe

Probe Dimensions & Characteristics			
Dimension	X [mm]	Y [mm]	Z [mm]
Field sensitive volume (FSV)	0.15	0.01	0.15
Position of the center of FSV (corresponding to FSP, see Fig.1 & Fig.2)	1.0 ± 0.1	-0.4 ± 0.05	-0.35 ± 0.1
Total Probe external dimensions	• 2.0 ± 0.1 - Longer, thinner part	• 0.5 ± 0.1 - Longer, thinner part	• 42.3 ± 0.2 - Longer, thinner part
	• 4.0 ± 0.1 - Shorter, thicker part of the probe	• 2.0 ± 0.1 - Shorter, thicker part of the probe	• 12.0 ± 0.1 - Shorter, thicker part of the probe
Angular accuracy of the axes	± 0.5° with respect to the reference surface		
CaH Cable	Shielded, with a flexible thin part near the probe		
1) Total length of the CaH cable:	<ul style="list-style-type: none"> • Standard: 2.0 m (Probe notation: 3H05x2x42-2) • Optional: X.X m (Probe notation: 3H05x2x42-xx) <p>Note: Various lengths are available upon request.</p>		

APPLICATION MANUAL FOR THE PROBE 3H1.1X2X42-XX**Warning: the Probe Tip is Fragile!**

The probe package is made of ceramics, and can be easily broken. Therefore, avoid any mechanical contact of the probe tip with other objects! Moreover, avoid the immersion of the probe of any liquid, and its exposure to moisture and aggressive gasses.

The following precautions shall help ensure that the transducer accurate calibration remains preserved:

The mounting of the probe should be carried out by application of very low pressure to its back-end and thin wires. If the probe head is clamped, the user should make sure that the substrate surface in contact with the reference plane of the probe is flat and covers as much of the probe reference surface as possible. Do not apply more force than required to hold the probe in its place.

In order to prevent rupture of the thin wires from the probe head, the user should fix and secure the probe cable in the proximity of the probe. The thin wires of the flexible section of the cable may be folded with care; repeated strong bending should be avoided.